

Serie 5.5.

Einfachkettenrad

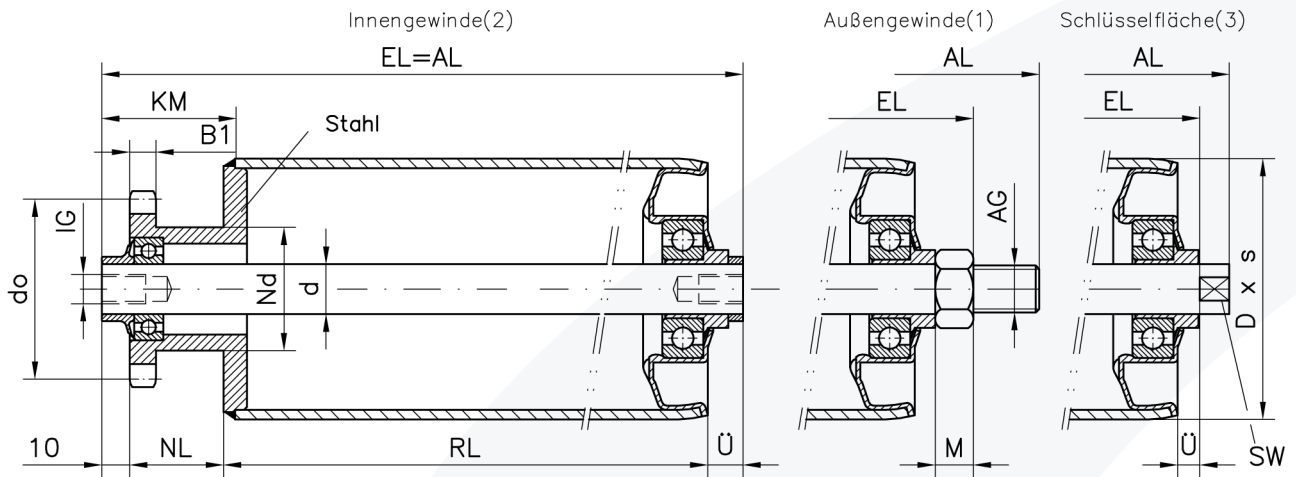

Rohrmat.	D x s = DD	d	Teilung	Zähnezahl	B1	do	Nd	NL	KM	Ü	M	AG	IG	SW	AL=	RL=	Bestellnummer
St St	89x3,25 108x3,25	17	1/2"	13	7	53,06	40	24	38	7	10	M12			EL+35	EL-51	5.5.DD.M.17.M.1.12.3.1.2.13
										7	13	M16			EL+45	EL-57	5.5.DD.M.17.M.1.16.3.1.2.13
										12,5			M10		EL	EL-47	5.5.DD.M.17.M.2.10.3.1.2.13
										12,5			M12		EL	EL-47	5.5.DD.M.17.M.2.12.3.1.2.13
										12,5				15x10	EL+20	EL-47	5.5.DD.M.17.M.3.15.3.1.2.13
										7	10	M12			EL+35	EL-59	5.5.DD.M.17.M.1.12.3.1.3.12
		7	13	M16			EL+45	EL-65	5.5.DD.M.17.M.1.16.3.1.3.12								
		12,5			M10		EL	EL-55	5.5.DD.M.17.M.2.10.3.1.3.12								
		12,5			M12		EL	EL-55	5.5.DD.M.17.M.2.12.3.1.3.12								
		12,5				15x10	EL+20	EL-55	5.5.DD.M.17.M.3.15.3.1.3.12								
		7	10	M12			EL+35	EL-57	5.5.DD.M.d.M.1.12.3.1.3.13								
		7	13	M16			EL+45	EL-63	5.5.DD.M.d.M.1.16.3.1.3.13								
	7	16	M20			EL+55	EL-69	5.5.DD.M.20.M.1.20.3.1.3.13									
	12,5			M10		EL	EL-53	5.5.DD.M.d.M.2.10.3.1.3.13									
	12,5			M12		EL	EL-53	5.5.DD.M.d.M.2.12.3.1.3.13									
	12,5				15x10	EL+20	EL-53	5.5.DD.M.d.M.3.15.3.1.3.13									
	7	10	M12			EL+35	EL-57	5.5.DD.M.d.M.1.12.3.1.3.15									
	7	13	M16			EL+45	EL-63	5.5.DD.M.d.M.1.16.3.1.3.15									
	7	16	M20			EL+55	EL-69	5.5.DD.M.20.M.1.20.3.1.3.15									
	12,5			M10		EL	EL-53	5.5.DD.M.d.M.2.10.3.1.3.15									
	12,5			M12		EL	EL-53	5.5.DD.M.d.M.2.12.3.1.3.15									
	12,5				15x10	EL+20	EL-53	5.5.DD.M.d.M.3.15.3.1.3.15									
	7	10	M12			EL+35	EL-57	5.5.DD.M.d.M.1.12.3.1.4.13									
	7	13	M16			EL+45	EL-63	5.5.DD.M.d.M.1.16.3.1.4.13									
7	16	M20			EL+55	EL-69	5.5.DD.M.20.M.1.20.3.1.4.13										
12,5			M10		EL	EL-53	5.5.DD.M.d.M.2.10.3.1.4.13										
12,5			M12		EL	EL-53	5.5.DD.M.d.M.2.12.3.1.4.13										
12,5				15x10	EL+20	EL-53	5.5.DD.M.d.M.3.15.3.1.4.13										

an dieser Stelle Rohrdurchmesser eintragen

an dieser Stelle Achsdurchmesser eintragen

stahlblank = 1

verzinkt = 2

← DD

← d

← M → M

← →

Serie 5.5.

Doppelkettenrad

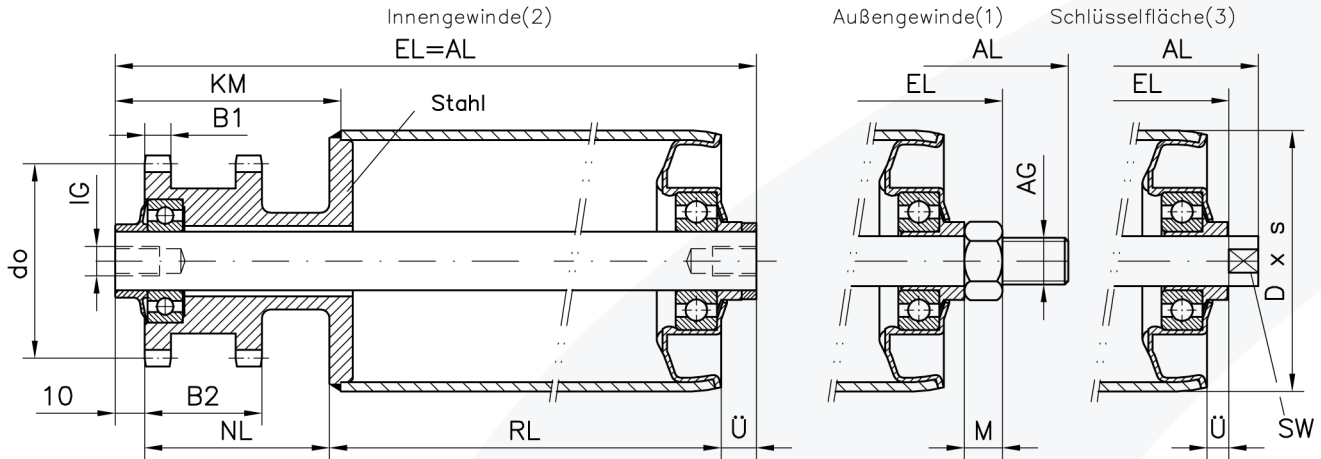

Rohr- mat.	D x s= DD	d	Teilung	Zähne- anzahl	B1	B2	do	Nd	NL	KM	Ü	M	AG	IG	SW	AL=	RL=	Bestellnummer	
St St	89x3,25 108x3,25	17	1/2"	13	7	27	53,06	40	44	58	7	10	M12			EL+35	EL-71	5.5.DD.M.17.M.1.12.4.1.2.13	
											7	13	M16			EL+45	EL-77	5.5.DD.M.17.M.1.12.4.1.2.13	
											12,5			M10		EL	EL-67	5.5.DD.M.17.M.2.10.4.1.2.13	
											12,5			M12		EL	EL-67	5.5.DD.M.17.M.2.12.4.1.2.13	
											12,5			15x10		EL+20	EL-67	5.5.DD.M.17.M.3.15.4.1.2.13	
											12,5								
			5/8"	13	9	40	66,32	37	63	77	7	10	M12				EL+35	EL-90	5.5.DD.M.d.M.1.12.4.1.3.13
											7	13	M16			EL+45	EL-96	5.5.DD.M.d.M.1.16.4.1.3.13	
											7	16	M20			EL+55	EL-102	5.5.DD.M.20.M.1.20.4.1.3.13	
											12,5			M10		EL	EL-86	5.5.DD.M.d.M.2.10.4.1.3.13	
											12,5			M12		EL	EL-86	5.5.DD.M.d.M.2.12.4.1.3.13	
											12,5			12x10		EL+20	EL-86	5.5.DD.M.d.M.3.15.4.1.3.13	
		17 20	15	9	40	76,36	55	63	77	7	10	M12				EL+35	EL-90	5.5.DD.M.d.M.1.12.4.1.3.15	
										7	13	M16			EL+45	EL-96	5.5.DD.M.d.M.1.16.4.1.3.15		
										7	16	M20			EL+55	EL-102	5.5.DD.M.20.M.1.20.4.1.3.15		
										12,5			M10		EL	EL-86	5.5.DD.M.d.M.2.10.4.1.3.15		
										12,5			M12		EL	EL-86	5.5.DD.M.d.M.2.12.4.1.3.15		
										12,5			15x10		EL+20	EL-86	5.5.DD.M.d.M.3.15.4.1.3.15		
			3/4"	13	10,8	40	79,59	59	63	77	7	10	M12				EL+35	EL-90	5.5.DD.M.d.M.1.12.4.1.4.13
											7	13	M16			EL+45	EL-96	5.5.DD.M.d.M.1.16.4.1.4.13	
											7	16	M20			EL+55	EL-102	5.5.DD.M.20.M.1.20.4.1.4.13	
											12,5			M10		EL	EL-86	5.5.DD.M.d.M.2.10.4.1.4.13	
											12,5			M12		EL	EL-86	5.5.DD.M.d.M.2.12.4.1.4.13	
											12,5			15x10		EL+20	EL-86	5.5.DD.M.d.M.3.15.4.1.4.13	
15	10,8	40	91,63	59	63	77	7	10	M12					EL+35	EL-90	5.5.DD.M.d.M.1.12.4.1.4.15			
							7	13	M16			EL+45	EL-96	5.5.DD.M.d.M.1.16.4.1.4.15					
							7	16	M20			EL+55	EL-102	5.5.DD.M.20.M.1.20.4.1.4.15					
							12,5			M10		EL	EL-86	5.5.DD.M.d.M.2.10.4.1.4.15					
							12,5			M12		EL	EL-86	5.5.DD.M.d.M.2.12.4.1.4.15					
							12,5			15x10		EL+20	EL-86	5.5.DD.M.d.M.3.15.4.1.4.15					

an dieser Stelle Rohrdurchmesser eintragen
an dieser Stelle Achsdurchmesser eintragen

stahlblank = 1
verzinkt = 2

